

INSTRUCTIONS FOR INSTALLING A TURRET SHELF AND DIVIDER KIT

CHECK THE PARTS RECEIVED IN THE KIT WITH THE PARTS LIST IN THESE INSTRUCTIONS. IF ANY PARTS ARE MISSING, CONTACT NATIONAL VENDORS' PARTS DEPARTMENT IMMEDIATELY.

Read these instructions carefully before installing the kit.
Retain these instructions for part numbers and for future reference.

PART NUMBER	DESCRIPTION	QTY
2222655	Screw - #6-32 x 3/8, PHS, TYPE 23, S/T, ZINC	16
4307034	Shelf - Product	18
4307035	Divider - Shelf	28
4307036	Retainer - Shelf	28
4307040	Installation Instructions	1

PART 1. INSTRUCTIONS FOR REMOVAL OF OLD PARTS

1. Rotate the turret until the section you are going to replace is facing the merchandiser front. See Figure 1.
2. Disconnect electrical power and open the door of the merchandiser.
3. The turret can be manually turned to the right or left. Push down on the solenoid plunger and turn the turret as necessary.
4. The kit contains parts quantities to replace two (2) sections, one zone, of the merchandiser. However, only one section at a time should be replaced. See Figure 1, Detail A.
5. Mark the top of each turret rail. The rails are located on both sides of the section being removed. This mark will aid you in reassembly. It is essential the rails are installed correctly. See Figure 1.
6. Remove four screws, two each from the top and bottom of each turret rail. See Figure 2.
7. A single wire retainer, in each turret rail, captures a tang on the vertical shelf wall. This wire retainer is located inside the rail near the fifth shelf. Hold a small mirror facing you behind the rail so that it reflects the inside of the rail. The wire retainer should be visible in the mirror. See Figure 2, Detail A.
8. Insert a flattip screwdriver under the wire retainer and push up until the retainer clears the tang. See Figure 3.
9. Pull the rails from the turret on both sides of the section being replaced.

10. Next, remove the divider retainers, shelf dividers, and product shelves from the turret.

PART 2. INSTRUCTIONS FOR INSTALLING THE KIT PARTS

1. Start at the bottom of the section and install a new product shelf (4307034). The new shelf installs exactly like the original shelf with the tabs at the rear fitting into the holes in the turret. The tabs on the right and left front, fit into the slots in the vertical wall. See Figure 4 and Figure 5.

NOTE

As you begin installation of the kit parts, you will see that some of the product shelves, on both sides of the section you are replacing, have slipped from the slots in the vertical walls. Don't do anything about this now. These shelves will be put back in place when the turret rails are installed.

NOTE

See Figure 4 for how to install the shelf dividers and retainers.

2. Install the required quantity of shelf dividers (4307035) that will satisfy the current tray configuration. If you change the quantity of dividers, remember to change the tray configuration programming.

3. Install the next shelf directly above the previous one.

4. Slide the divider retainers (4307036) in place so they capture the guide on top of the divider and the guide on the bottom of the shelf.

5. Continue installing shelves, dividers, and retainers until all shelves are in place.

6. Before putting the top divider retainers (4307036) in place, snip off the tab on the top front of only the top retainers. This will allow the top retainers to seat flush with the front of the drum.

7. Locate the wire retainer inside one of the turret rails and be sure the top of the rail is up. See Figure 1.

8. With the long open side of the turret rail facing the turret, press the rail into place. The rail should capture the vertical wall and the adjoining ends of the shelves in the section not being replaced. Move each shelf, as necessary, vertically or to the right or left in order to get it into the rail.

9. When all the shelves are held by the rail and the rail is flush with the front of the shelves, push the wire retainer down until it will go no further. Pull out on the rail to make sure the wire retainer is engaging the tang on the vertical wall. See Figure 2 and 3.

10. Install the four screws removed in Part 1, step 6.

11. Return to Part 1 and repeat steps 3 through 10 for the remaining section. Then, in Part 2, repeat steps 1 through 10.

12. Repeat steps 7 through 10, Part 2 for the remaining turret rail.

13. Close the merchandiser door and restore electrical power.

14. Change the program configuration if necessary. Refer to the Set-Up Guide for the appropriate procedure.

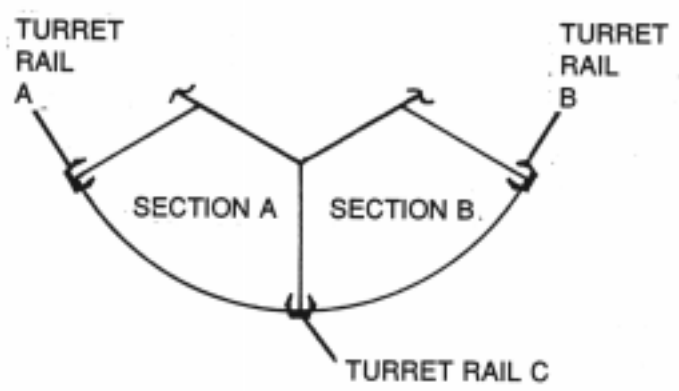
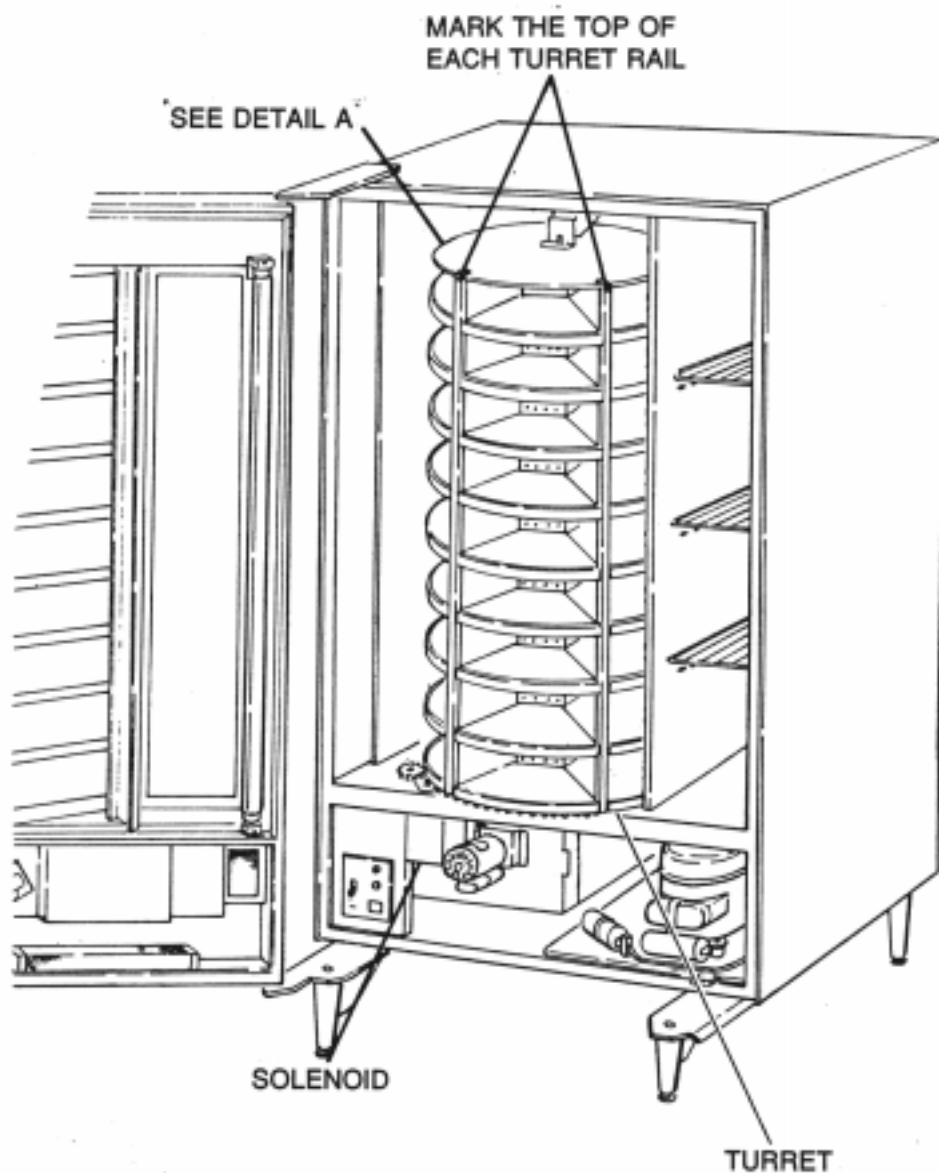

DETAIL A

NOTES

1. Replace only one section of a zone at a time.
2. Install turret rail C last.

Figure 1.

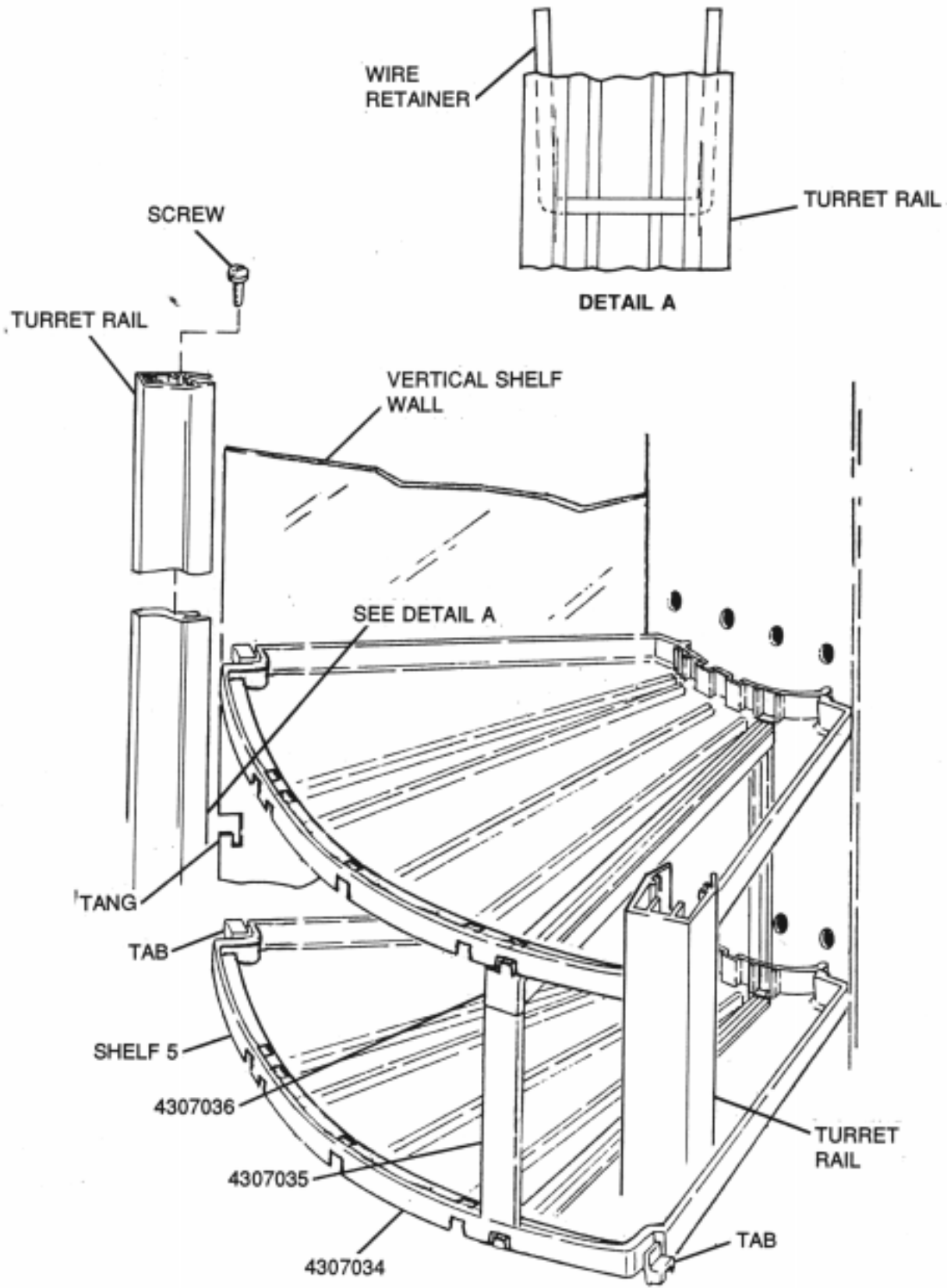

Figure 2.

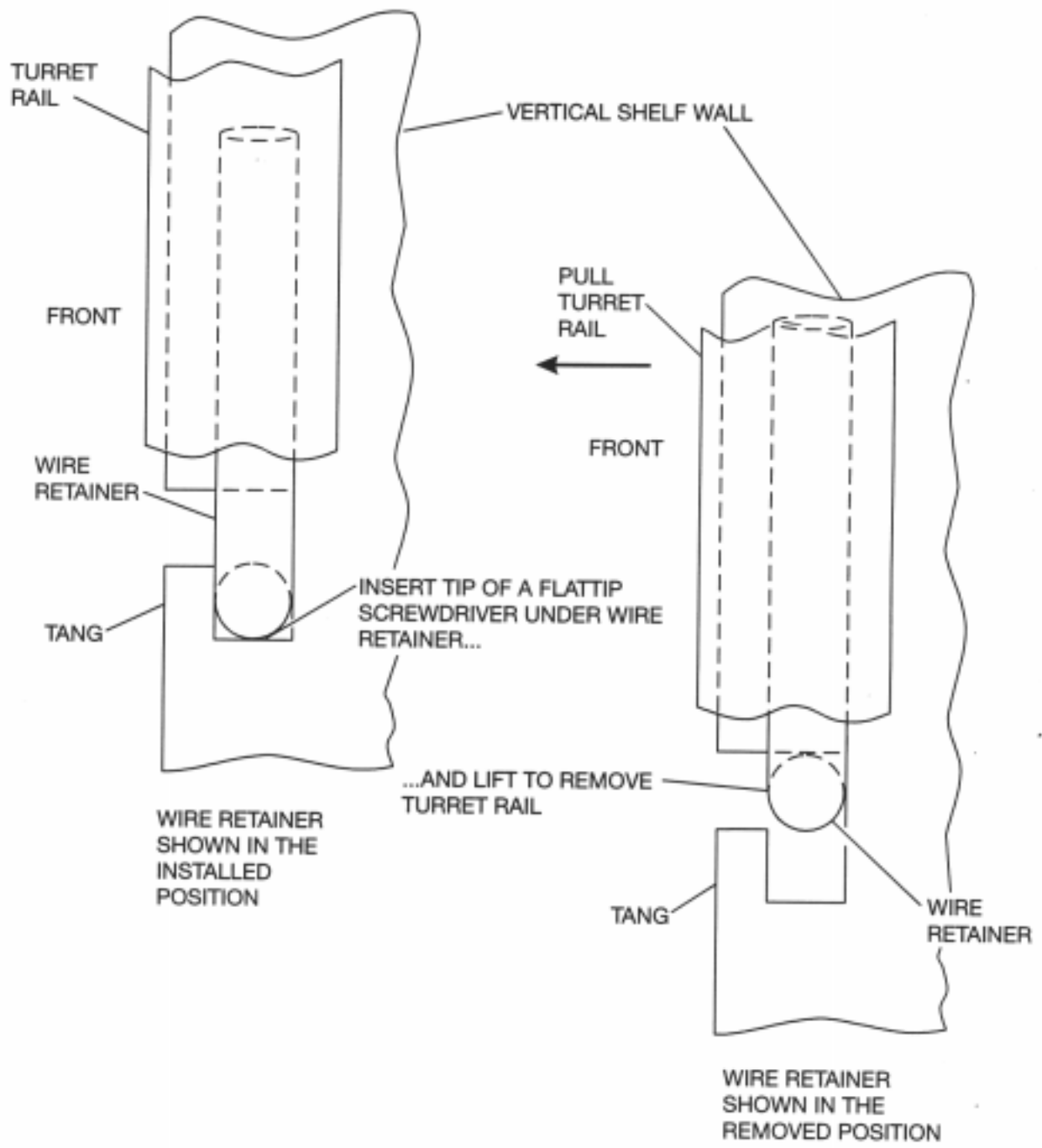
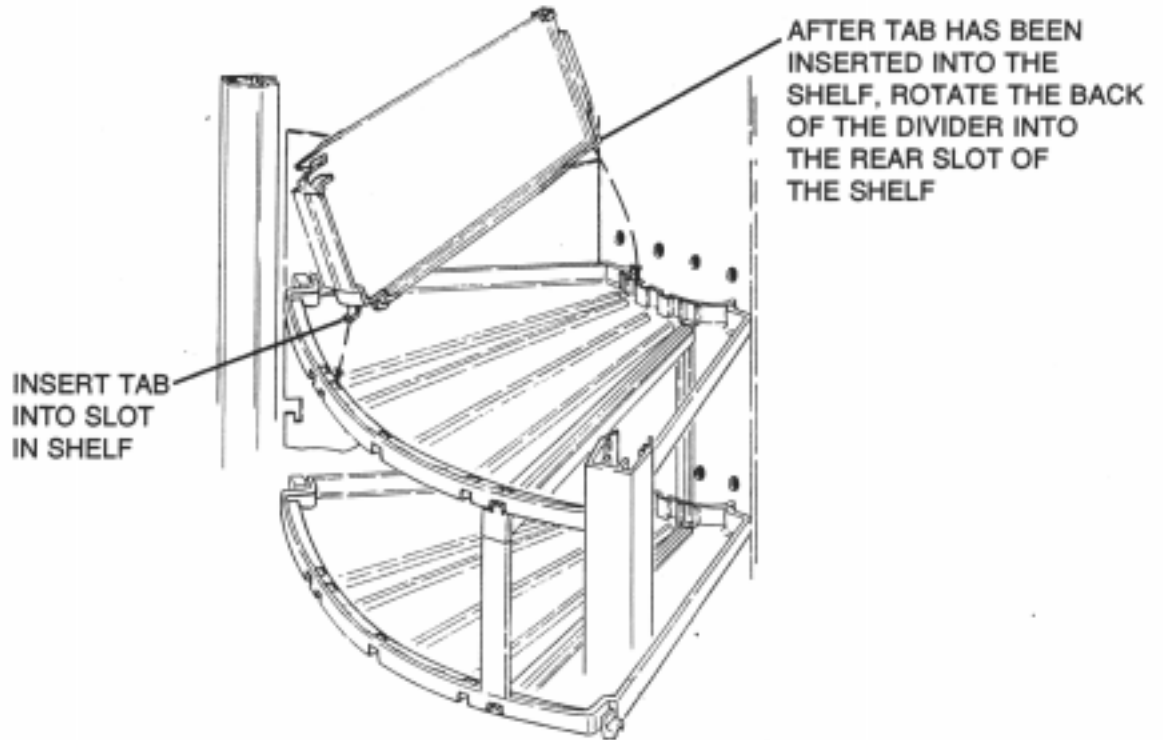

Figure 3.



SNIP OFF THIS TAB ON THE TOP RETAINERS ONLY

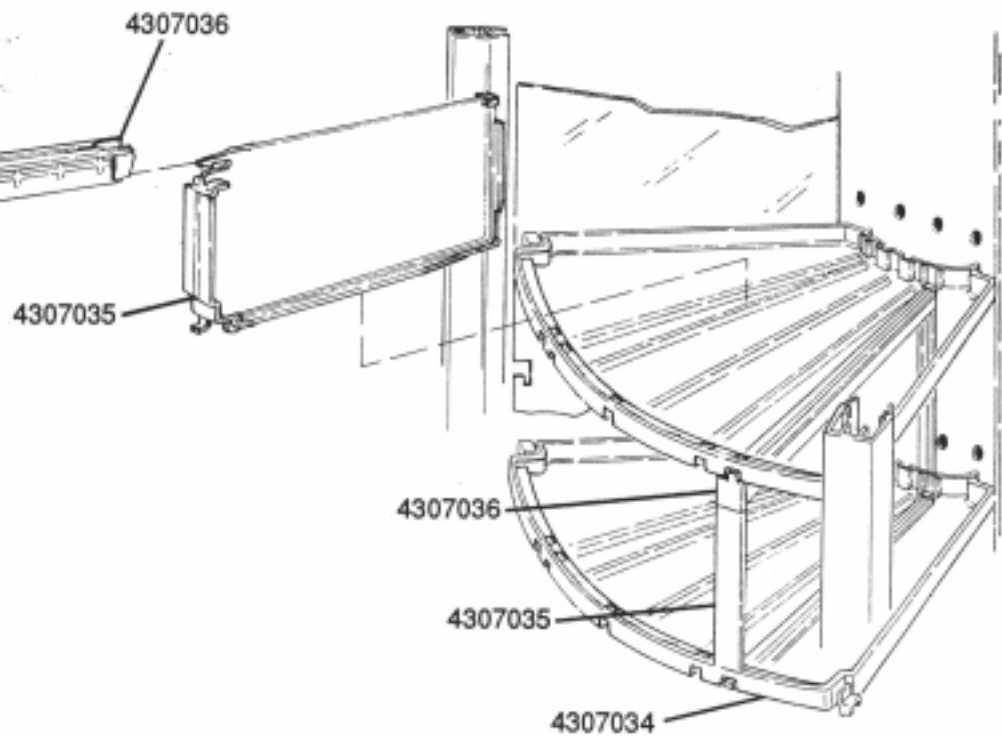

Figure 4.